

## Crystal Ladder Filter Program "Dishal"

This Program was written to provide a simple and convenient way of calculating the necessary component values to construct crystal ladder filters of the Lower-Sideband type. It accepts any number of crystal resonators (poles) from **2 to 14**.

### There are a few points to be aware of:

- 1 The program covers only Butterworth- and Chebychev filter types (up to 3db PB ripple).  
(A subprogram for the accurate calculation of the values for Cohn-Type filters is also provided)
- 2 All filter crystals are assumed to have identical parameters (fs, Lm, Cm, Cp).
- 3 The crystals are treated as lossless resonators.

However, the program provides very accurate results for all relevant filter parameters and component values.

An additional graphic display of the resultant filter response curve allows a fast assessment of the filter performance.

### Input fields

All necessary inputs are concentrated in the upper bar:

### Crystal Parameters

You can select either the crystal motional inductance **Lm** or the motional capacitance **Cm**. The other value is then calculated according to the value of the crystal **Series frequency fs**. Also required is the value of the crystal's holder capacitance **Cp**.

You may notice that there is no input field for the crystal parallel frequency **fp**. This was omitted because the measurement of fp does not yield very reliable results due to its sensitivity to stray capacitance and termination resistance. Hence, fp is calculated from the above parameters.

### Filter Parameters

#### - 3db-Bandwidth (BW):

The 3db bandwidth can be chosen up to the maximum possible bandwidth. This maximum BW is calculated but not displayed directly. However, if it is exceeded, an error message is issued showing the maximum possible BW. Additionally, a hint message with the max. BW info is shown when the mouse pointer is moved into the B3db field.

#### - Passband ripple:

A passband ripple of 0db generates a Butterworth response, any value from >0 to 3db generates a Chebychev response.

- **Number of crystals:** any number from **2 to 14** xtals (poles) is accepted.

- **Frequency Span:** can be freely chosen between **>0 and 400kHz** for the graphic display.

The **"Calculate"** button or the **<RETURN>** key can be used to calculate and update the results after any change of inputs.

Any invalid or missing input will generate an error message.

## Result fields

### Xtal parameters

Here, the motional inductance  $L_m$  and capacitance  $C_m$  of the crystal is shown besides the respective series and parallel resonance frequencies  $f_s$  and  $f_p$ . The holder capacitance  $C_p$  is not shown here but can be read off the input field. The calculated motional  $C_m$  or  $L_m$  is displayed with a resolution of at least 6 decimal places. This has nothing to do with the actual accuracy but allows the representation of the exact crystal series frequency if these data are to be used in a simulation program.

### Filter parameters

The following parameters are shown in the upper part of this area:

the **Filter type** (Butterworth / Chebychev),  
the **Passband ripple**,  
the Source / Load **Impedance**, (appears in **red** colour when the Impedance is **>3000 Ohm**)  
the **number of xtals**,  
and the resultant **Center frequency**

Also, the resultant **bandwidth** values are shown for:  
**-6db, -20db, -40db, -60db, -80db, and -100db**

### Coupling (Shunt) capacitances

These are the calculated values for the coupling capacitors to achieve the design bandwidth. The subscripts ("Ck12", "Ck23", etc.) describe their position between the respective xtals.

**Note:** The value for a respective Ck appears in **red** colour if Ck is **smaller than 10pF**.

### Tuning (Series) capacitances

These are the capacitors in series with the xtals to tune them to the common mesh frequency of the filter. Their subscripts ("Cs1", "Cs3", etc.) also describe their connection to the respective xtals.

Besides the capacitance values, the individual (always positive) frequency offsets of  $f_s$  caused by the tuning capacitances are shown. If crystals with the respective frequency offsets can be supplied then the tuning capacitors can be omitted. The "reference frequency" for these offsets is always the frequency of xtal #2 (and xtal #n-1) in the filter – the only ones without a tuning (series) capacitance.

→ For more details see the part: **"Mesh Frequency"** (Appendix)

You will notice that only **half** of the necessary coupling and tuning capacitances are listed.

This is sufficient because the topology for the Butterworth and Chebychev filters is always symmetrical. Therefore, the coupling capacitance  $C_{k_{1,2}}$  is identical with  $C_{k_{n-1,n}}$ , and so forth.

The following pictures of filters with odd and even numbers of poles illustrate this property.

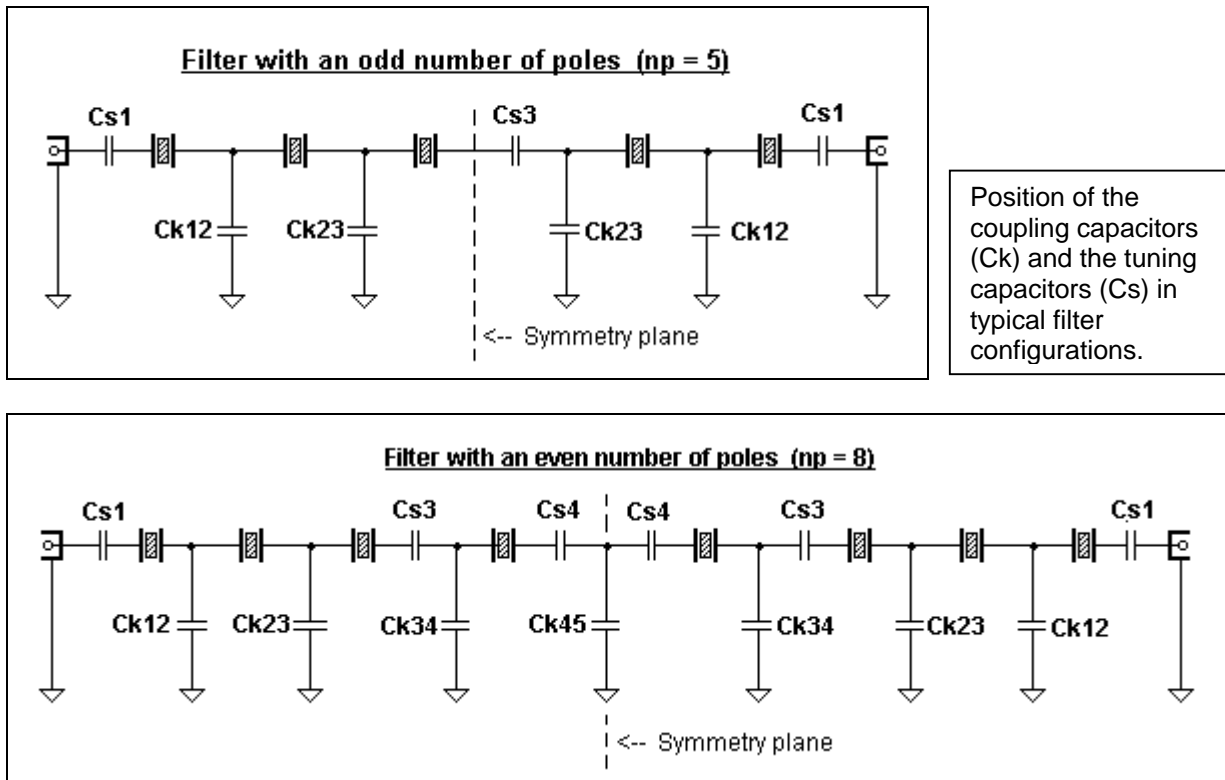

## The Graphic Display

The graphic display field shows the resultant filter response curve. The filter curve is always centered on the calculated center frequency "fm". Based on the selected frequency span of up to 400kHz, the respective plus and minus frequency offsets are also displayed. The response curve can also be displayed with linear scaling by hitting the **LOG→Lin** button below the "Calculate" button in the Input bar.

The **ultimate attenuation** value is shown and will also appear as a red line if it is within the display range of 0 -100db. The median of the upper- and lower filter slopes is shown as a green line ("Symmetry Axis"). It shows the deviation of the filter curve from a symmetrical response.

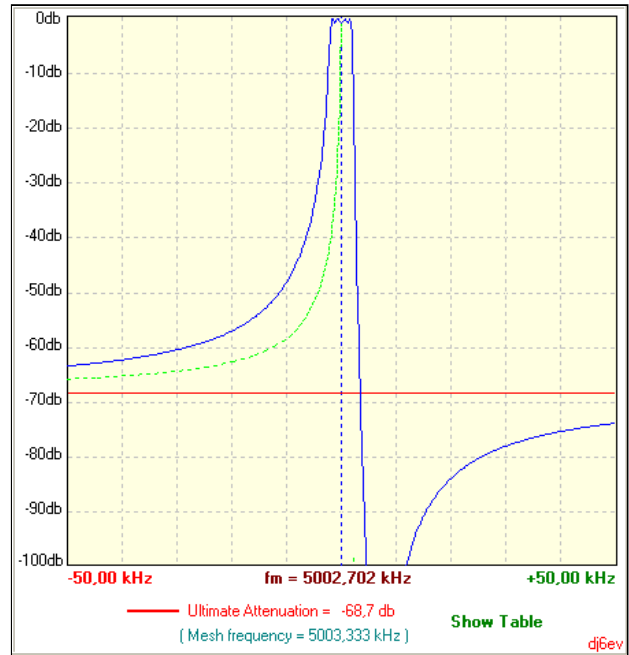
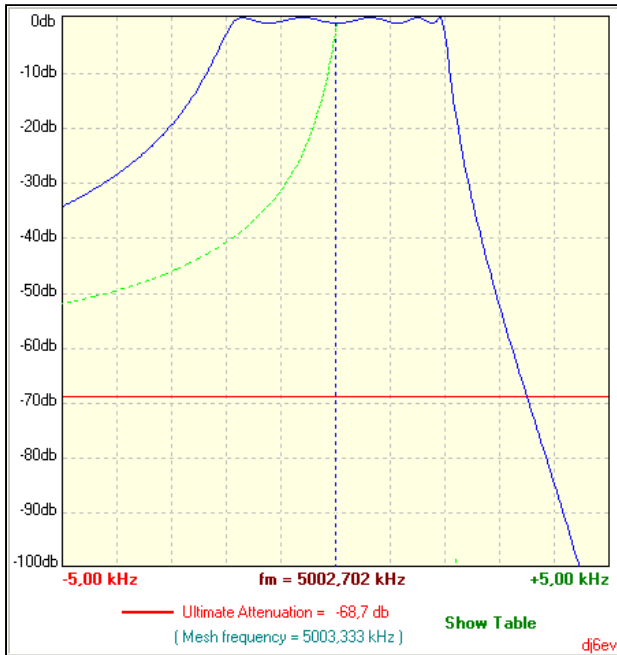

A 5-MHz 5-pole, 1db Chebychev filter response, displayed with frequency spans of 10kHz and 100kHz

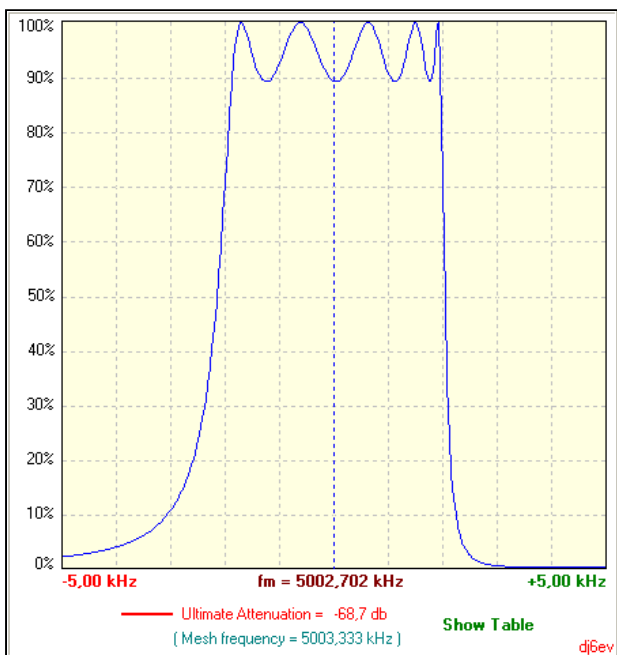

Att(db)	fLow(kHz)	fHi(kHz)	fret(kHz)	Bw(kHz)
-1	5000,826	5004,667	---	3,842
-2	5000,758	5004,686	---	3,929
-3	5000,702	5004,702	---	3,999
-6	5000,555	5004,740	---	4,185
-10	5000,354	5004,790	---	4,436
-15	5000,054	5004,858	---	4,805
-20	4999,668	5004,937	---	5,268
-25	4999,165	5005,026	---	5,861
-30	4998,500	5005,127	---	6,627
-35	4997,600	5005,238	---	7,638
-40	4996,349	5005,358	---	9,010
-45	4994,525	5005,488	---	10,963
-50	4991,674	5005,625	---	13,951
-55	4986,674	5005,769	---	19,095
-60	4975,823	5005,918	---	30,095
-65	4935,363	5006,071	---	70,708
-70	---	5006,227	5204,890	---
-75	---	5006,384	5047,238	---
-80	---	5006,541	5029,069	---
-85	---	5006,698	5022,083	---
-90	---	5006,852	5018,407	---
-95	---	5007,002	5016,153	---
-100	---	5007,148	5014,639	---

Ultimate Attenuation = 68,69 db  
6db / 60db shape factor = 7,191

The response curve, shown in the linear display

The calculated results in tabular form. Here, they are shown as absolute frequencies vs. attenuation

## The Menu bar

### SaveWindow

A click on this label generates a bitmap picture of the whole program window and saves it in the program folder as "Filter.bmp". To indicate that the picture is generated, the graphic display changes its colour for a fraction of a second. (A copy of this bitmap is also available in the Windows clipboard). All calculated data - including the value of the mesh frequency - and the response curve are contained in the picture and can be used for further evaluation. If several different pictures are required, one has to either rename the file (recommended) or to move it into another folder because any new picture is overwriting the existing one without warning.

### Cohn

Filter designs using the "minimum-loss" coupling method publicized by Seymour Cohn [7] have become quite popular – especially for CW filters – despite their known deficiencies like uncontrollable passband ripple and relatively high group delay distortion. The advantages are the simple design, using equal values for the resonators and the coupling capacitors, and the lower insertion loss together with relatively steep filter slopes.

A click on this label opens a new window with a small program which is independent of the main program. It serves only as an easy-to-use calculator for the values of the coupling capacitance and the filter termination.

However, this program also applies the Dishal method, i.e., the effects of the crystal parallel capacitance  $C_p$  are accurately taken into account. Hence, it delivers equally exact calculation results for the coupling and termination values.

### Xtal

Opens a drop-down menu, containing two programs for the easy calculation of the crystal parameters, and a third one for crystal tuning:

#### 3db-Method

This one is based on the values measured with a passive test set, using a precision signal generator and detector or a network analyzer. It assumes that the "3-db" method is used. A detailed description about this measurement method and how to construct such a very useful setup and it's application can be found on the web page of K8IQY under the title "Precision VXO" :

<http://www.k8iqy.com/testequipment/pvxo/pvxopage.htm>

This is just one example of the many available articles about crystal parameter measurements.

#### Note:

The [3db-method](#) program expects the direct voltage ratio "Uout/Uin [%]" as an input to calculate the loss resistance  $R_m$ . If  $R_m$  is determined directly by substitution as described by K8IQY, then the input value for the above input field can be adjusted until the given  $R_m$  is shown in the result field.

(G3UUR-Method – see next page)

### G3UUR-Method

This is probably the most popular method, using an oscillator circuit with a switchable capacitor in series with the crystal which allows the calculation of the basic xtal motional inductance and capacitance. Its description can be found in many publications and on the Internet. The only disadvantage is that the crystal loss resistance and the resulting quality factor  $Q_u$  cannot be derived with this method.

### Xtal Tuning

This program allows the calculation of individual series tuning capacitances to achieve equal mesh frequencies when the available xtals cannot be matched for identical series resonances. Its application with a calculated example is shown in the appendix.

### Table

The calculated results can also be displayed in tabular form. When "Table" is selected, then three fields are opened: "Relative Freqs", "Show/Close Table " and "Save Table as Text". Here you can switch to the table display which appears in the graphic area.

However, it may be more convenient to use the button "Show Table" below the graphic diagram which switches between the graphics and the table display. Clicking on "Relative Freqs" changes the table display between the representation of absolute and relative frequency values.

The table list can be saved as a text file "Tables.txt" in the program directory. In this case, the xtal- and filter parameters are added to the list, together with the values of all coupling and tuning capacitances.

### LC-Match

Selecting "LC-Match" opens a separate program window to calculate the values for an appropriate LC matching network to match the filter to the external source and load impedances. This may be a better choice for specific cases rather than the transformer method. Both possible versions for this network – the Low-Pass and the High-Pass topology and their values are shown. The calculation assumes resistive impedances and also requires that  $R_1$  is always smaller than  $R_2$ . Otherwise, an error message is displayed. If the difference of the filter and external impedances is equal or smaller than 1:1.02 ( → return loss 40db), then the message "No matching network necessary" appears.

Note: When this program is called, it will automatically take the frequency and termination values from the main program and calculate the resulting values for the LC networks. Of course, any other input values can be chosen for calculations after start-up.

### Cs2Cp

This subprogram can be used to transform the termination series capacitance  $C_{s1}$  into its parallel equivalent. The termination impedance is also changed accordingly. At startup, the calculated values for frequency, impedance and  $C_{s1}$  are taken from the main program but can be freely changed for a general application of the program.

### Colours

This add-on menu allows you to change the colours of the graphic display components.

## Appendix

### The filter "Mesh" and Center frequency

In normal bandpass filters of the mesh (ladder) type, the filter center frequency and the mesh frequency are identical. This is **not** the case with the ladder bandpass filters using crystals. (Thanks to Jack Hardcastle, G3JIR, who pointed this discrepancy out)

The reason for this is, once again, the inevitable parallel (holder) capacitance  $C_p$  which causes not only an asymmetry in the stopband but also in the passband. Thus, because the center frequency is defined as the median between the 3db points, the mesh frequency is always slightly higher in a lower-sideband ladder filter (in the upper-sideband topology it is always lower). The following picture of a 3-pole Chebychev filter illustrates this effect – here, the mesh frequency is 195Hz higher than the center frequency.

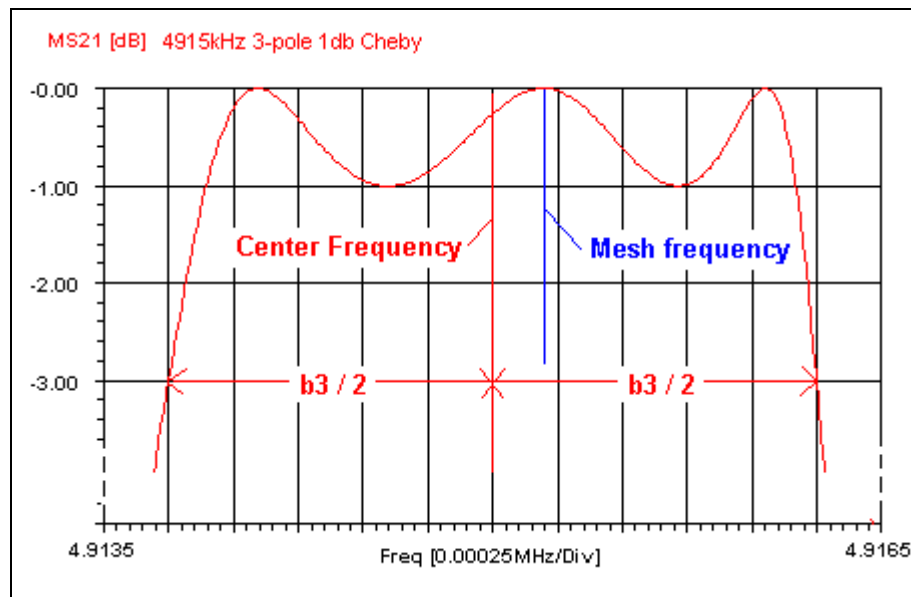

The mesh frequency is shown as a hint message whenever the mouse pointer is moved over either the "Center frequency" number in the Filter Parameter field or over the same number below the graphic display.

Note: If a picture is taken with "SaveWindow", the mesh frequency is shown below the graphic diagram instead of the "Symmetry Axis" label.

The values of the tuning C's provided by the program ensure equal frequencies of all meshes. Only, if any additional tuning of individual crystals is desired the following info might be helpful:

- 1) The filter mesh frequency is always defined by the second mesh in the filter (and the second last which is identical), being the highest frequency because the crystal is connected in series with the smallest coupling capacitances on both sides. All other meshes are then tuned to this reference mesh frequency with additional series tuning caps.
- 2) The application of the Xtal Tuning program in the "Xtal" menu for an individual tuning of xtal mesh frequencies is described in detail on the following pages.

## Crystal Tuning with the "Xtal Tuning" program

It is always recommended to select crystals with identical series resonance frequencies (and, of course, identical motional inductances) for a ladder filter. This makes the design of filters with the Dishal program extremely easy and yields results which provide the best fit to the theoretical response. The variation of the xtal frequencies should not exceed  $\pm 2\%$  of the desired bandwidth. A spread of up to  $\pm 5\%$  is only acceptable if larger ripple values can be tolerated.

However, there may be cases where only crystals with a wider frequency spread are available. Within certain limits, those crystals can be individually "tuned" with series capacitances which differ from the calculated values for the ideal case. For this purpose, the respective equivalent offset frequencies are shown in the Dishal program besides the values of the series (tuning) capacitances  $Cs_x$ .

The xtal tuning program is very easy to use because the necessary frequency offset information is already provided by the Dishal program. The resulting filter passband curve may slightly deviate from the ideal one. This can be a small increase of the passband ripple, sometimes together with minor changes of bandwidth and center frequency. However, these effects are still negligible compared to the errors introduced by actual component tolerances and crystal losses. An explanation of the various reasons for this behaviour is beyond the scope of this description.

The tuning method is explained with a typical example.

Let's assume 8 crystals with the following arbitrary series frequencies (kHz):

#1: 4999.670, #2: 4999.895, #3: 5000.010, #4: 5000.120, #5: 5000.235, #6: 5000.320,  
#7: 5000.485, #8: 5000.680. (this is an unusually large total spread of 1010Hz)

We will construct an 8-pole filter with a 3db bandwidth of 2.5kHz and a ripple value of 0.5db, using the above crystals.

The first step is to select a crystal from the list which lies somewhere in the middle of the frequency distribution. Therefore, we take crystal #4 (5000.120kHz) for the reference mesh #2 which also defines the nominal series frequency  $f_s$  for the Dishal program.

Now, we will first calculate the filter assuming identical crystals with the selected series resonance of 5000.120 kHz. Typical values for the motional inductance  $L_m = 70\text{mH}$  and a holder capacitance of  $C_p = 3.7\text{pF}$  are used. The Dishal program will yield the following result:

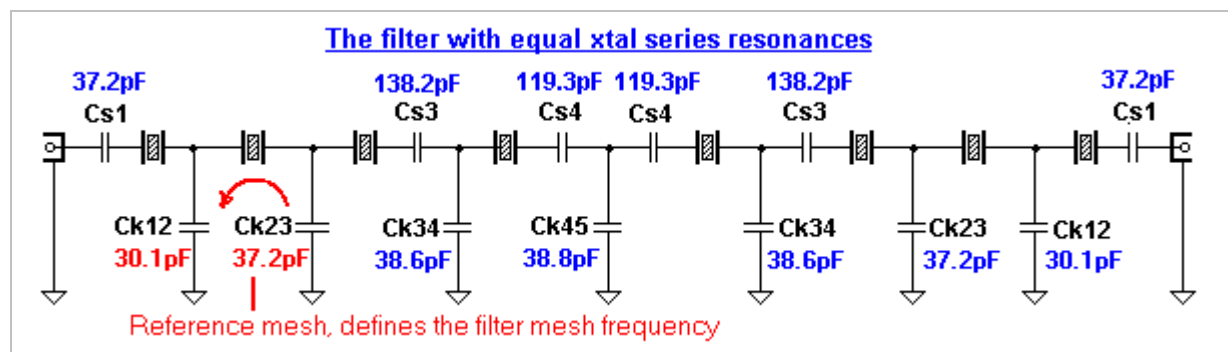

The meshes #2 and #7 are the only ones without a series capacitance. They define the mesh frequency of the filter which is the highest due to the smallest coupling capacitances connected to them. Consequently, their frequency offset is Zero by definition and is not listed. All other crystals must be tuned to this mesh frequency by their series capacitances  $Cs_1 \dots Cs_4$ .

The program provides us with the values of the coupling capacitors which define the filter properties and are also important for the calculation of the necessary tuning capacitors. The values for Cs1 to Cs4 in the above picture are of no interest because we must change them anyway due to the different crystal frequencies. However, in the list below, the corresponding frequency offsets are shown as well. These are needed for the tuning process.

Tuning (Series) Capacitances (pF)		equiv. Freq. Offset (Hz)
Cs1=	37,2	709
Cs3=	138,2	179
Cs4=	119,4	208

The values in the "equiv. Freq. Offset" fields are now used for the tuning procedure with the "Xtal Tuning" program. The values of the coupling (shunt) capacitors as shown above will not be altered.

We can now activate the "Xtal Tuning" program in the Menu drop-down list. For user convenience, all necessary initial parameters are automatically imported from the main Dishal program at startup. The only fields which should be changed in the tuning process are "Current Xtal Series Freq." and "Nominal Offset".

Since crystal #4 is used for mesh #2, we select the crystal #3 (5000.010kHz) for the mesh on the other side of the filter (mesh n-1 = #7). We know that this mesh is also defined with a nominal offset of Zero. We put the values for the frequency ('Current Xtal Series Freq.!) and the 'Nominal Offset' into the Xtal-Tuning program and get the following result:

<div style="border: 1px solid gray; padding: 5px; margin-bottom: 5px;"> <p>Ck12 <input type="text" value="30,1"/> pF Ck23 <input type="text" value="37,2"/> pF &lt;- Reference Mesh (#2), defining Fmesh</p> <p>Select either Lm or Cm of xtal</p> <p><input checked="" type="radio"/> Lm <input type="text" value="70"/> mH</p> <p><input type="radio"/> Cm Cm = <input type="text" value="14,47376"/> fF</p> <p><input type="text" value="5000,120"/> kHz Nominal Xtal Series Freq.</p> <p><input type="text" value="3,7"/> pF Xtal Holder Capacitance Cp</p> <p><input type="text" value="5000,010"/> kHz Current Xtal Series Freq.</p> </div> <div style="border: 1px solid gray; padding: 5px;"> <p>Current - Nominal [Hz] <input type="text" value="-110"/> <span style="margin-left: 100px;"><b>Nominal Offset in (Hz)</b> <input type="text" value="0"/></span></p> <p>Actual Xtal offset [Hz] <input type="text" value="110"/></p> <p style="text-align: center;"><b>Tuning Capacitance (pF)</b> <input type="text" value="217"/> <span style="margin-left: 50px;"><b>Calculate</b></span></p> </div>	<p>← Coupling values of mesh #2, taken from the Dishal program</p> <p>← This frequency is used as the basic series freq. "fs" in the Dishal program for the calculation of the coupling (and basic series) capacitances.</p> <p>← The respective offset freq. as calculated and shown in the list for the series (tuning) Csx. <b>Special case here: Zero</b></p>
--	---

The mesh #7 requires a series capacitance of 217pF.

We proceed further by looking at the end meshes (#1 and #8) which require the largest offset. It is obvious that we choose the crystals with the highest positive deviation from the nominal frequency of 5000.120kHz. These are the crystals #7 and #8 (5000.485 and 5000.680kHz). The required offset for the end meshes is 709 Hz. We put the numbers into the program and get:

<div style="border: 1px solid gray; padding: 5px; margin-bottom: 5px;"> <p>Select either Lm or Cm of xtal</p> <p><input checked="" type="radio"/> Lm <input type="text" value="70"/> mH</p> <p><input type="radio"/> Cm Cm = <input type="text" value="14,47376"/> fF</p> <p><input type="text" value="5000,120"/> kHz Nominal Xtal Series Freq.</p> <p><input type="text" value="3,7"/> pF Xtal Holder Capacitance Cp</p> <p><input type="text" value="5000,680"/> kHz Current Xtal Series Freq.</p> </div> <div style="border: 1px solid gray; padding: 5px;"> <p>Current - Nominal [Hz] <input type="text" value="560"/> <span style="margin-left: 100px;"><b>Nominal Offset in (Hz)</b> <input type="text" value="709"/></span></p> <p>Actual Xtal offset [Hz] <input type="text" value="149"/></p> <p style="text-align: center;"><b>Tuning Capacitance (pF)</b> <input type="text" value="189"/> <span style="margin-left: 50px;"><b>Calculate</b></span></p> </div>	<p>Because the crystal has already an offset of 560Hz, an additional tuning of only 149Hz is required. The value of the calculated series-C is therefore <b>189 pF</b>.</p> <p>For the crystal with 5000.485kHz at the opposite end of the filter, the program yields <b>80.1 pF</b> to achieve the same nominal offset.</p>
--	--

[We can now calculate the rest of the necessary tuning capacitances which produces this filter \\*:](#)

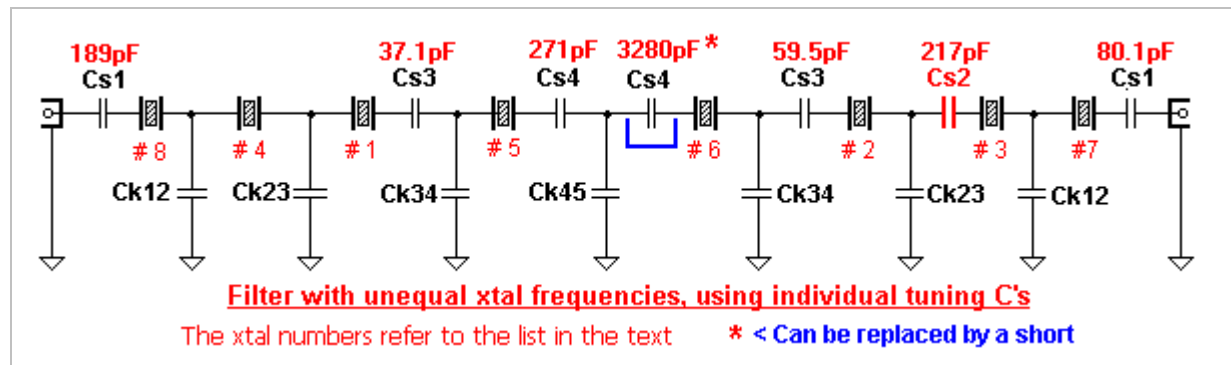

This is just one example of how to proceed with crystals having different series frequencies. The degree of freedom is limited by the fact that the crystals can only be pulled upwards in frequency by capacitors. Therefore, it can happen in the process that the starting values lead to a situation where the inherent crystal offset is already larger than required by any of the filter meshes. In this case, we have to repeat the whole process with a higher crystal frequency as the starting value.

However, any recalculation can be performed in a very short time frame with the two programs.

The crystals should not be shifted excessively in frequency. The crystal quality factor  $Q_u$  is reduced with an increasing offset, i.e. decreasing value of the series capacitance. Hence, a warning is given by the program when the capacitance value goes below 10pF.

Of course, there are other proven tools available for the calculation and tuning of individual filter meshes. Wes Hayward, W7ZOI has written such a tool to calculate the necessary values with the program "FineTune" which comes with the book "EMRFD" [5] as part of "LADPAC2002" or its older counterpart "MeshTune" (DOS) which was supplied with the book "RF Design" [6]. Because the approach is very different from the method used here, it is recommended that you read the respective introductions carefully.

Somebody with a fearless mind wanting to construct nearly ideal filters by tuning each individual mesh should read the article by J. Makhinson, N6NWP [8] which describes the basics and the necessary steps in detail. However, it should be noted that N6NWP is also using crystals with more or less identical parameters as a starting point. His "fine-tuning" is performed to compensate for all tolerances to achieve such excellent filter responses as shown in his article. This is quite time consuming and requires numerous accurate measurements as well.

\* The filter could also be designed without any tuning capacitors if we had a set of crystal pairs with the frequency offsets as calculated by the Dishal program. However, the crystals must still have more or less identical values for  $L_m / C_m$  (max.  $\pm 2\%$ ). In this example, the required crystal frequencies would be:

2x 5000.120kHz for the meshes 2 and 7(n-1) (as the reference frequency  $f_s$ )  
 2x 5000.829kHz for the meshes 1 and 8 (+ 709 Hz)  
 2x 5000.299kHz for the meshes 3 and 6 (+ 179 Hz)  
 2x 5000.328kHz for the meshes 4 and 5 (+ 208 Hz)

Even here, we get some deviations from the ideal passband, but they are extremely small.

## [Some practical hints](#)

The program "Dishal" assumes lossless components for the filter calculation.

Of course, actual filters exhibit an insertion loss and rounding of the passband edges due to the losses in the crystals (loss resistance  $R_m$ ) and, to a minor degree, losses in the capacitances. This leads to a slightly smaller 3db-bandwidth than calculated. However, this effect is normally very small compared to the deviations caused by component tolerances. An example: a 4915kHz 8-pole filter was designed for a 2.4 kHz bandwidth at 3db, and showed a real bandwidth of 2.36 kHz. At 6db down, the difference was even less (<20Hz). If you need a guaranteed minimum bandwidth then you should simply use the desired 5- or 6db bandwidth of a filter as the design (3db) bandwidth.

And there is also the influence of the crystal holder stray capacitances in the order of 1 to 2pF which should be subtracted from the calculated coupling capacitances.

It is always very helpful to transfer the calculated data into a good simulation program. Thus, one can verify the ideal filter curve by defining lossless crystals, and investigate the influence of real losses and deviations from the ideal capacitance values and termination resistances.

Horst Steder, DJ6EV November 2007 (revised January 2009)

## [Acknowledgement](#)

I would like to thank Jack Hardcastle, G3JIR, for the many productive discussions and exchange of ideas over the past years regarding this interesting topic. He also motivated me to overcome my laziness and transfer my age-old DOS program into this Windows version, and to add various tools to it during the recent months.

## [References \(besides many other sources\)](#)

- [1] "Calcul et realisation des filtres à quartz en echelle"  
Patrick Magnin F6HYE, Bernard Borcard F3BB  
Radio – REF, April 1990
- [2] "Computer aided ladder crystal filter design"  
Jack A. Hardcastle G3JIR  
Radio Communication, May 1983
- [3] "Two new equations for the design of filters"  
M. Dishal  
Electrical Communications , Vol.3, December 1955
- [4] "Modern network theory design of single-sideband crystal ladder filters"  
M. Dishal  
Proceedings of the IEEE, Vol.53 , September 1965
- [5] "Experimental Methods in RF Design" ("EMRFD")  
W. Hayward, W7ZOI R. Campbell, KK7B B. Larkin, W7PUA  
ARRL publication No.288, 2003
- [6] "Introduction to Radio Frequency Design"  
Wes Hayward, W7ZOI  
ARRL publication No.191, 1994-96
- [7] "Dissipation Loss in Multiple-Coupled-Resonator Filters"  
Seymour B. Cohn  
Proceedings of the IRE, August 1959
- [8] "Designing and Building High-Performance Crystal Ladder Filters"  
Jacob Makhinson, N6NWP  
QEX No.155, January 1995